

# Performance

## Trends'

# Swirl Meter For Flow Bench Testing

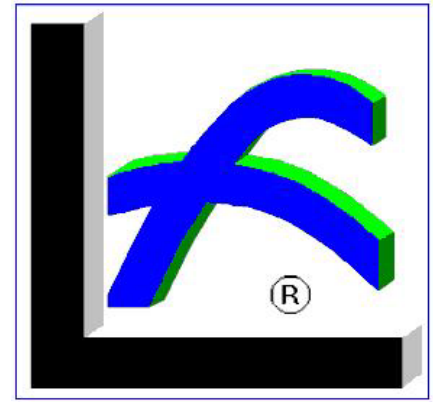

### Theory:

For years engine builders have seen heads which flow great on the bench get beat on the dyno and the track by heads with less flow. Obviously there is more to cylinder heads than just great flow numbers.

One important aspect for great performing heads is the motion of the incoming fuel/air charge. Generally heads with good motion or swirl will perform better because they will burn the fuel/air mixture faster. (continued on back page)

### Description:

Our Swirl Meter has steadily been refined. In 2011 we switched to a more compact display box featuring a USB connection, both for power and data logging by our Port Flow Analyzer software. It's features include:

- Microprocessor based with user menu for configuration.
- USB communications and power for data logging via our Port Flow Analyzer software.
- All digital communication. No calibration required.
- Large digit, backlit display with user selectable "time out" to save power. Displays from -9999 to 9999 RPM in 1 RPM resolution.
- **Performance Trends exclusive feature: Negative numbers indicate counter clockwise rotation when viewed from top.**
- Button to hold to display maximum, minimum and average swirl RPM over either a 5 or 10 second period.
- User selectable display for either Current or Average Swirl.
- User selectable 0-5 or 0-3 volt analog output. (Requires optional cable.)

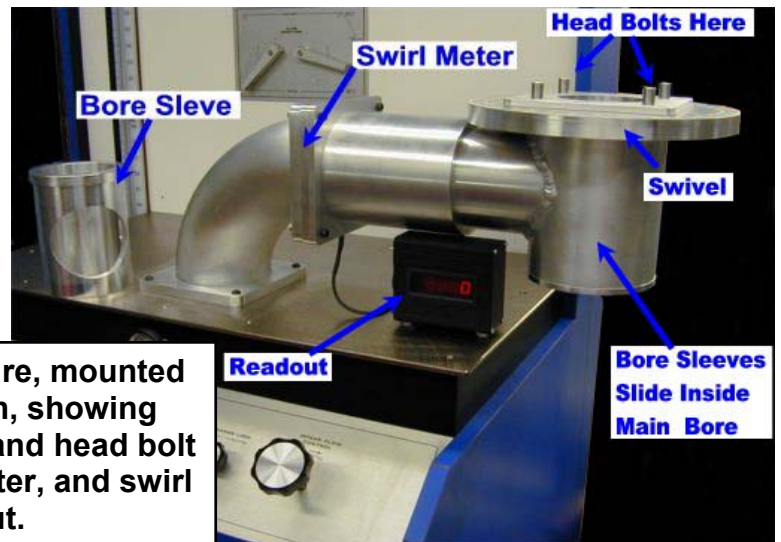

**Tumble Fixture, mounted to flow bench, showing bore sleeve and head bolt pattern adapter, and swirl meter readout.**

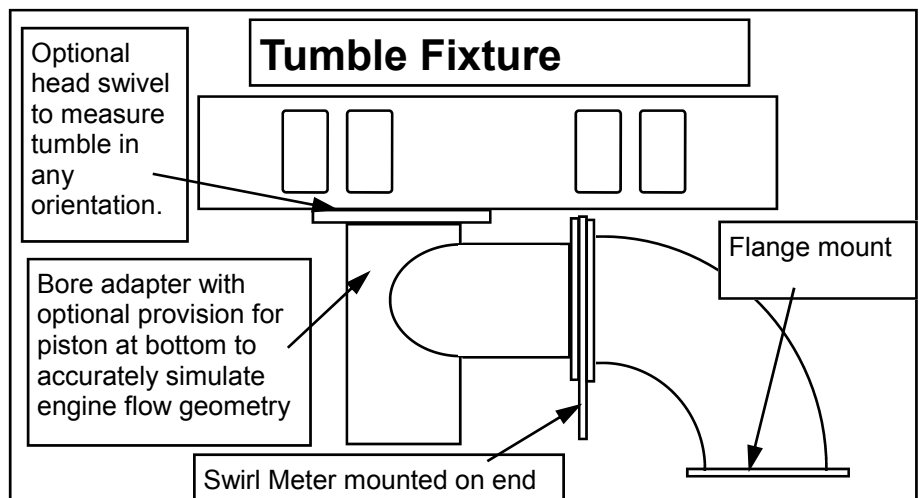

Other features of Performance Trends' Swirl Meter include:

- Low "flow restriction" design lets you measure swirl at the same time as intake flow (big time savings).
- Rugged aluminum and stainless steel design with 20,000 RPM rated bearings designed to hold up in a shop environment.
- Optional analog output for our Black Box II flow bench data logger or SuperFlow's Flow Com (tm).
- 5" mounting holes designed for standard SuperFlow and other manufacturer's flow benches.
- Low friction bearings provide for more repeatable readings.
- RPM measurement method eliminates calibration drift of "torque type" swirl measurements.
- Tumble fixture available for more "in depth" measurements and analysis.
- Compatible with our Port Flow Analyzer software to let you easily record Swirl, Swirl Stability, and Tumble directly from SuperFlow's FlowCom (tm) electronic flow bench interface or our Black Box II flow bench data logger.

The Swirl Meter mounts between the bore adapter and the flow bench and records the gross axial, circular motion of intake. The standard 3.75" paddle wheel is designed for bores in the 4 to 4.5 inch range. Custom paddle wheel sizes and designs are available from Performance Trends to cover bores from 2.5 to 4.5 inches in .25 inch steps.

The Swirl Meter does not restrict flow significantly (usually less than 1 CFM at 400 CFM flow). Record the Swirl RPM as you run your flow test and record CFM on the intake port. (There is no use recording swirl when flowing the exhaust port.) Some users make 2 tests, the first without the Swirl Meter to more accurately record CFM without the slight restriction, then another test with the Swirl Meter to record Swirl RPM only. You may want to check the difference in CFM with and without the meter on your heads and decide if 2 separate tests are necessary.

It is important to realize that swirl readings are still relatively new to race engine development and there is no "magic" Swirl RPM to design for. Tests have indicated that you can have **too much** swirl for some engines, and some successful engine builders actually design for low swirl. **Do not** simply design for maximum swirl without regard to flow or how the engine behaves on the dyno.

Swirl readings will change with test pressure and CFM flow, distance meter is spaced from the head, clearance between paddle wheel and bore adapter, weather, bearing friction and temperature, etc.) It's important to be repeatable in your testing procedure when checking for minor changes in swirl. When comparing Swirl readings with other engine builders, be sure to consider these differences also. Performance Trends is developing corrections and recommendations as swirl readings become more common.

## Swirl Meter Theory, cont:

The Swirl Meter lets you measure intake mixture motion on your flow bench to track differences between just good heads and **Great** heads. No doubt you've heard about "fast burn" heads or the advantage of dual plug heads which also burn faster. When heads burn faster you gain in 2 ways:

- The engine will require less spark advance. By firing the mixture closer to TDC there will be less cylinder pressure to fight the piston rising to reaching TDC.
- The burn will be completed sooner after TDC, creating higher pressures after TDC and thus more power.

Both of these effects result in a more efficient engine **making more power out of the same amount of air and fuel**. In racing you want to maximize the efficiency of the engine. This is especially important in restricted classes of racing where restrictor plates severely limit air flow.

### Swirl Meter Readout

No minus sign means the swirl is clockwise as viewed from the top (head).

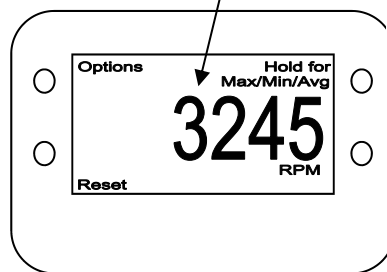

### Swirl Meter

Mounted between flow bench and cylinder bore adapter.

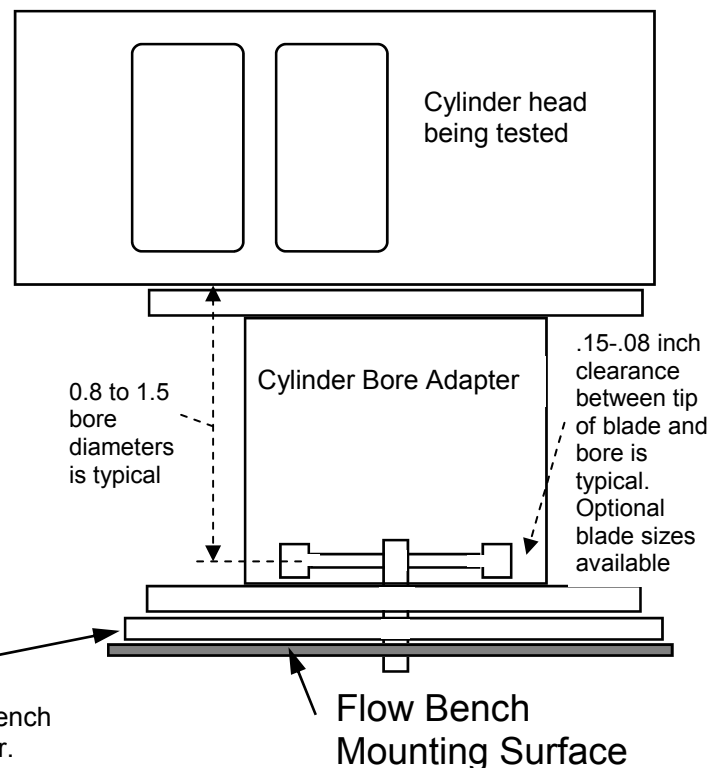

# USB Swirl Meter Configuration

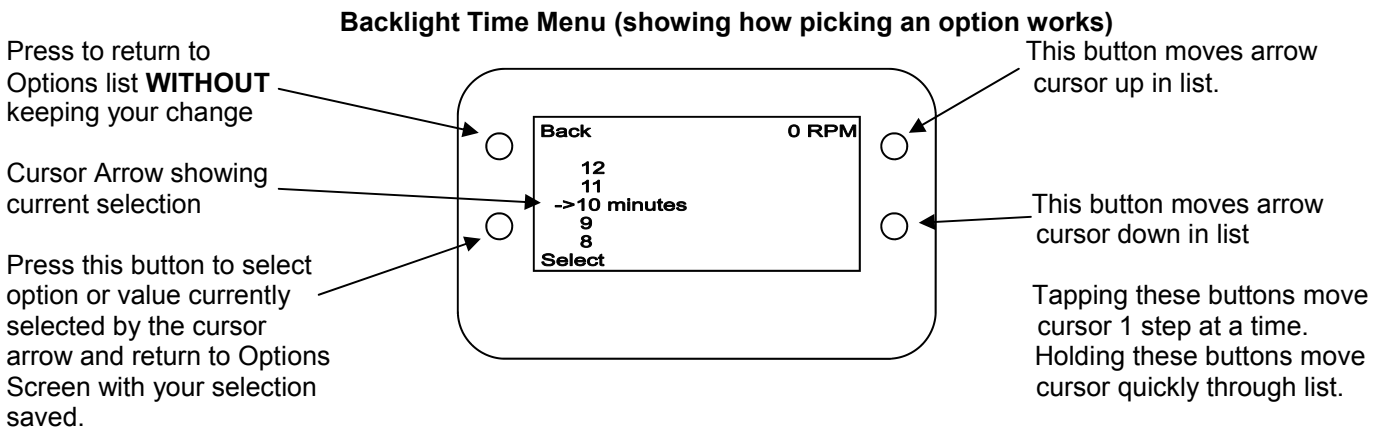
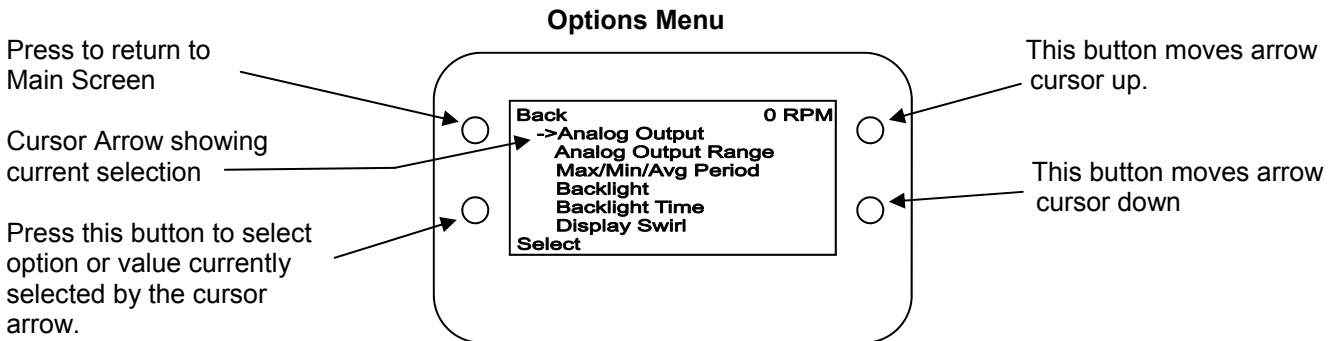
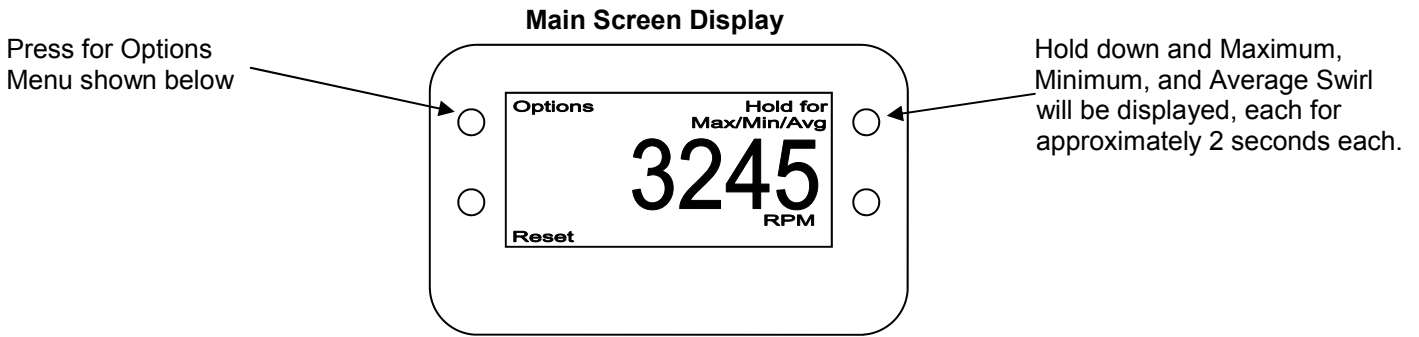

## Definitions of Options:

- Analog Output selects either 0-5 volt output (Black Box II or pre-USB Super FlowCom) or 0-3 volts for USB FlowCom
- Analog Output Range selects if the Analog Output is for either a particular RPM range. For example, +/- 2500 RPM means the 0-5 volt output (if Analog Output option is set to 0-5 volts) will produce 0 volts for -2500 RPM, 2.5 volts for 0 RPM and 5 volts for 2500 RPM.
- Max/Min/Avg Period selects the time period over which these values are calculated.
- Backlight selects what motion or button press will turn on the backlight for the display.
- Backlight Time selects the minutes the backlight will remain on after it is turned On.
- Display Swirl lets you select to display the Current Swirl (updated about every 0.5 seconds) or Average Swirl (more stable) but updates only every 5 or 10 seconds as selected with the Max/Min/Avg Period option.

# USB Swirl Meter Setup Sheet

Plug in the Swirl Meter via the USB cable to one of your computer's USB ports. You should hear the USB connect sound, and your computer should say "Found new hardware". Fig 1.



It may ask if it should connect to the internet to find a driver. Say No, and when it asks for you for a CD, put the Performance Trends Installation CD in your computer (the same CD which contains your Port Flow Analyzer software). **Wait about 60 seconds to see if the Installation Wizard comes up.** If it does, then click on OK for the intro messages, then click on Stop in the lower left corner to shut the Installation Wizard down. With the Installation Wizard gone, follow the instructions in the Found New Hardware Wizard.

When complete, it should now say "Your hardware is ready to use."

Now go into the Port Flow Analyzer software, and into the Flow Bench screen. Fig 2. (Note: Only Pro version supports Swirl Meter.) Click on See Details (calibrations) button for screen in Fig 3. Then click on Swirl/Tumble Meter Type and choose Micro USB as the Type. Then

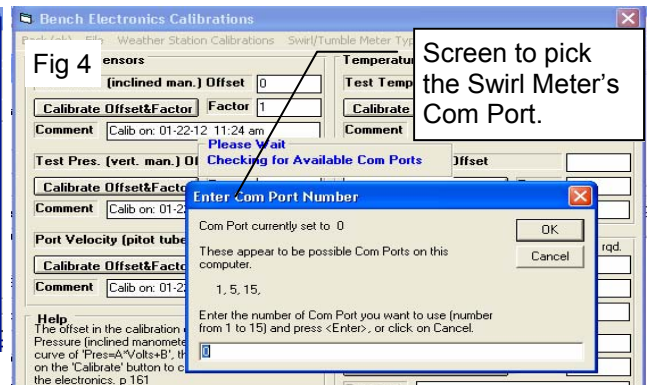
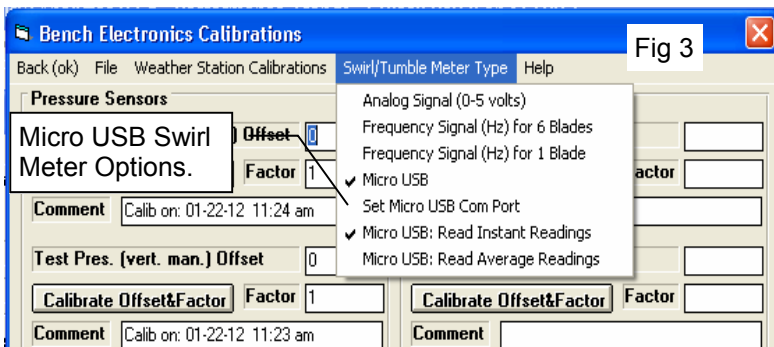
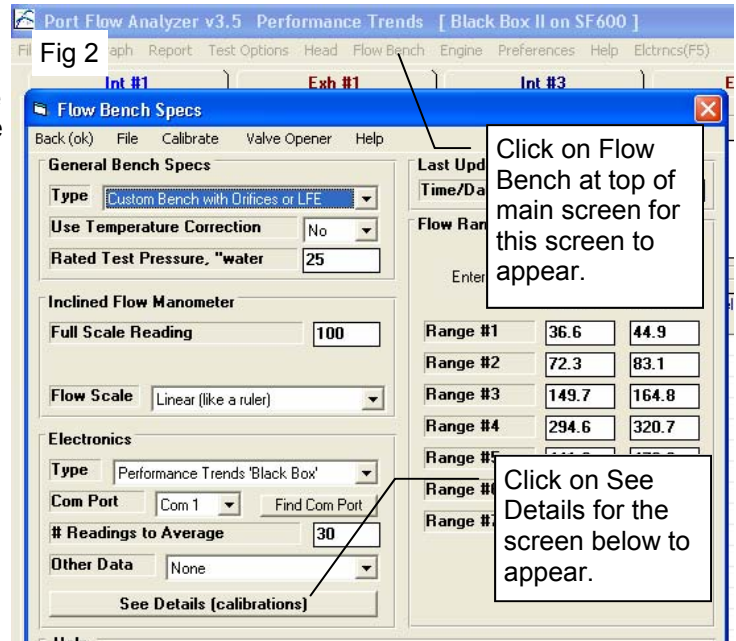

you can click on Set Micro USB Com Port to pick the Com Port your Swirl Meter is connected to. A new screen appears showing possible Com Ports. See Fig 4. Tip: If you disconnect the swirl meter cable and wait, and click this option again, the Com Port number which is now gone is most likely the port for this swirl meter. From this drop down menu, you can also choose for Instant Readings (quick changing) or Average Readings (stable, but slow updating). No other calibration is required.

Note: The Port Flow software can only use com ports from 1 to 15. If your computer happens to assign the Swirl Meter to a com port higher than 15 (rarely happens), you must go into your computer's Control Panel / Device Manager and manually change the com port number to something lower, we recommend something from 4 to 15.

To obtain Swirl readings in your test data, you must also choose to include Swirl (or Swirl & Range) as shown in Fig 5. Click on Test Options at top of main screen to obtain the Test Options screen.

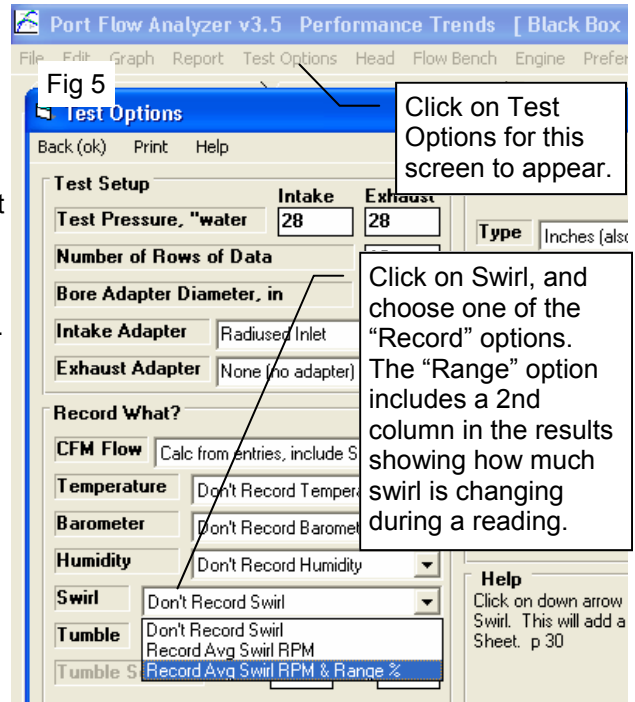

# Special Extended Swirl Blade for Small Diameter Bore Adapters

